

# IntelliStation® Family of Digital Mixing Solutions

Smart Domestic Hot Water Solutions  
for Commercial and Institutional Facilities



**IntelliStation® Jr.**

**IntelliStation®**

**POWERS™**  
A WATTS Brand





## The IntelliStation Family

**IntelliStation** digital mixing solutions enable the safe, efficient delivery of hot water in commercial and institutional facilities. Both products have the same functionality, but at different flow capacities. The IntelliStation, with its large-capacity valves, is designed for use in hospitals, universities, and large hotels.

**The IntelliStation Jr.** valves have a smaller flow capacity and are best suited for use in nursing homes, middle/high schools, and small hotels. Both products provide the advantages of digital technology for efficiently controlling and monitoring domestic water at safe, consistent temperatures.

# Making the Move to Digital Water Mixing

Today, the most widely employed approach to managing hot water delivery uses thermostatic mixing technologies. Digital mixing technology enhances safety, conservation, and energy efficiency.

**Choose the Right One for Your Application**



	IntelliStation	IntelliStation Jr.																
<b>Applications</b>	Hospitals, Full/Select Service Hotels, Universities/Colleges, Prisons, Large Office, Multi-Family	Nursing Homes, Assisted Living, Ambulatory Care, Select Service/Budget Hotels, K-12 Schools, Jails, Office																
<b>Fully Assembled w/Recirculation</b>	Standard	Optional																
<b>Capacity (gpm) @ 10 psid</b>	<table border="0"> <tr> <td>3/4"</td> <td>Not Available</td> </tr> <tr> <td>1"</td> <td>Not Available</td> </tr> <tr> <td>1-1/2"</td> <td>85</td> </tr> <tr> <td>2"</td> <td>135</td> </tr> </table>	3/4"	Not Available	1"	Not Available	1-1/2"	85	2"	135	<table border="0"> <tr> <td>3/4"</td> <td>23</td> </tr> <tr> <td>1"</td> <td>55</td> </tr> <tr> <td>1-1/2"</td> <td>71</td> </tr> <tr> <td>2"</td> <td>125</td> </tr> </table>	3/4"	23	1"	55	1-1/2"	71	2"	125
3/4"	Not Available																	
1"	Not Available																	
1-1/2"	85																	
2"	135																	
3/4"	23																	
1"	55																	
1-1/2"	71																	
2"	125																	
<b>Temperature Control</b>	+/- 2°F to ASSE 1017	+/- 2°F to ASSE 1017																
<b>Minimum Hot Water Supply</b>	2°F above set point	2°F above set point																
<b>Auto-Balancing</b>	Standard	Standard																
<b>Compliance</b>	ASSE, IAPMO, cUPC, BTL, NSF, UL	ASSE, IAPMO, cUPC, BTL, NSF, UL, CE																
<b>Native BAS</b>	Standard, BACnet, Modbus	Standard, BACnet, Modbus																
<b>Integrated Recirculation Pump Control</b>	Optional	Not available																
<b>Flow &amp; Energy Monitoring</b>	Optional	Not available																
<b>Sensors:</b>																		
Mixed Outlet Temperature	Standard	Standard																
Mixed Outlet Pressure	Standard	Not available																
Inlet Temperatures	Standard	Not available																
Inlet Pressures	Standard	Not available																
Return Temperature	Standard	Not available																
Return Pressure	Standard	Not available																
<b>Temperature Limits/Alerts</b>	Standard	Standard																
<b>Sanitization Mode</b>	Standard	Standard																
<b>Controller</b>																		
Passcode Protected	Standard	Standard																
Touch Screen Interface	Standard, 4-Color	Standard, 4-Color																



# IntelliStation®

## Key Capabilities

- Digital temperature regulation within +/-2°F to ASSE 1017, even during low and zero demand periods
- Field configurable without the need for a laptop or special software

## By intelligently controlling and monitoring the water recirculation loop, the IntelliStation:

- Supports energy conservation through more efficient water temperature management—and in turn reduces energy costs
- Compatible with building automation systems to support integrated building management



## Smart Controller

The control ships with a 3.5-inch full-color LED touchscreen interface.

The IntelliStation allows you to select the desired hot water temperature and control and monitor your water distribution system. For even greater control, IntelliStation should be installed as part of an ASSE-compliant water distribution system, including point-of-use mixing valves at each fixture in the plumbing system.<sup>1</sup>

Hospitals



## The Intelligent Way to Control Water Temperature

The IntelliStation is the smart way to deliver mixed water throughout a hot water recirculation loop. The digital water mixing and recirculation solution can be integrated in a building automation system (BAS) to allow facilities managers to remotely monitor and control water temperatures.

Factory assembled and tested as complete system

Actuator is located outside of mixing valve where it is not affected by potential water leakage from valve.

Internal capacitor initiates valve position to full cold upon power and is not reliant on batteries. Closes hot water in the event of power failure or cold water failure.

Mixed Water Outlet

Return

Smart controller with 3.5" full-color touchscreen interface for ease of use and clarity of critical data.

Temperature and pressure sensors on hot/cold water inlet supplies, mixed water outlet, and tempered water return.

Integrated recirculation pump (engineer specified)

Integrated check valves prevent cross flow

Hot Water Inlet

Cold Water Inlet

To Boiler

### OTHER FEATURES

- Lead Free\* listed to NSF 372
- Optional energy efficiency package monitors GPM and BTUs
- ASSE 1017 certified, cUPC listed, UL listed, BACnet Testing Laboratory (BTL) listed

*\*The wetted surface of this product contacted by consumable water contains less than 0.25% of lead by weight.*

## Typical Applications

### Universities



### Hotels





# Tempered Water Delivery Redefined

## Domestic Hot Water

1. PVI® Conquest® water heater
2. Powers™ IntelliStation® digital mixing system

## Watts Water Management

3. SmartStream® UV disinfection
4. Big Bubba® water filtration
5. OneFlow® anti-scale
6. Watts Backflow Preventer



**SELEXIT™**

**SIZE. SELECT. CONFIGURE.**

Use the Watts Selexit™ sizing and configuration platform to easily determine which IntelliStation best suits your facility.

## Point-of-use applications

Combine the IntelliStation with these other quality mixing products from Powers to ensure fixture temperatures are comfortable and safe.



Individual Bath/Whirlpool (ASSE 1070)



LFLM495

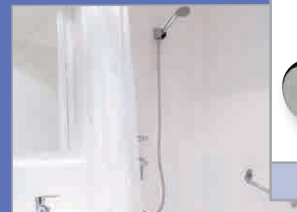

Individual Showers (ASSE 1016)



E420 • E700



## Watts Brands Combine for a Multi-barrier Approach to Legionella

Watts provides the right mix of expertise, experience, and solutions to help diminish the threat of Legionella, as well as other pathogens in premise plumbing. These water quality and heating solutions complement the IntelliStation to provide options for creating and maintaining a water management plan.

## SmartStream® UV Ultraviolet Disinfection System

- Limits Legionella reproduction in an easy to maintain and energy efficient process
- Provides affordable way to protect against bacteria Legionella and other waterborne bacteria and pathogens
- Removes dissolved substances such as hardness minerals, iron, manganese, and tannin
- Protects plumbing system equipment while ensuring production of safe, high quality water

## OneFlow® Anti-scale System

- Limits the buildup of scale in pipes and valves, reducing nourishment to Legionella and possibly helping other Legionella risk mitigation solutions work more efficiently and effectively
- Prevents mineral build-up inside pipes, fixtures and appliances
- Does not require salt, chemicals or electricity
- Has no regeneration cycle to flush water down the drain

## Big Bubba® Non-metallic Filter Housings

- Effectively remove sediment, assisting other equipment to function properly.
- Reduce sediment and sediment shadows, which increases effectiveness of UV
- Commercial filtration with optional activated carbon cartridge removes chlorine bad tastes, foul odors and sediment
- Pre-filtration for reverse osmosis equipment
- 100% efficient because no backwashing is required

## PVI Conquest® Water Heaters

- Provide up to 97% thermal efficiency operating up to 140°F, the storage temperature recommended by ASHRAE, OSHA and the CDC to control Legionella.

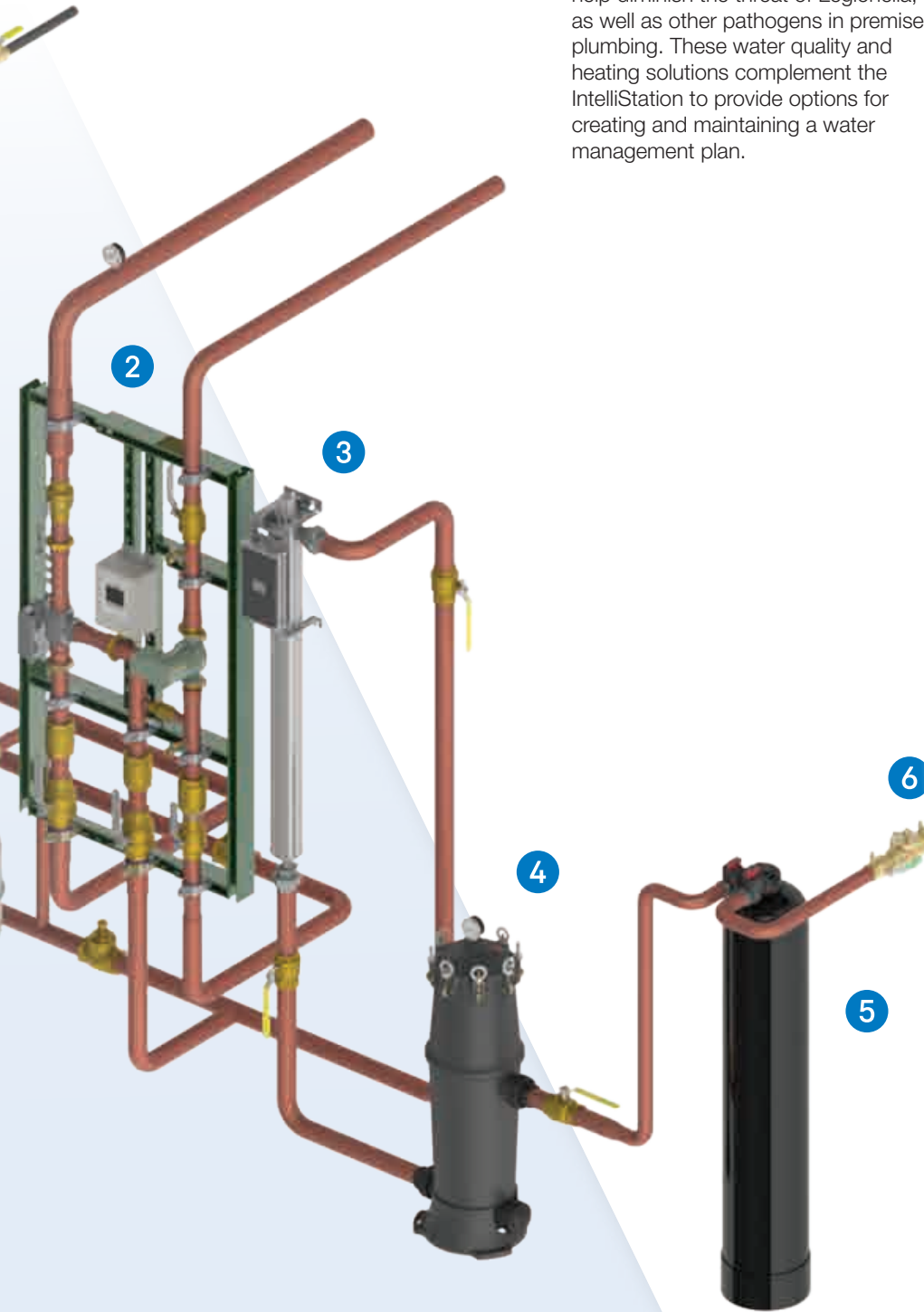

Lavatory Sinks (ASSE 1070)



TempTAP™



LFe480



Safety Shower • Eye Wash (ASSE 1071)



ES/ETV Series



# IntelliStation® Jr.

The newest member of the IntelliStation® family provides safe hot water consistently and on demand, wherever and whenever it is needed, in nursing homes, middle/high schools, small hotels and similar facilities.

Three-way lead free ball valve

Fast acting temperature sensor (Mixed Outlet)



ASSE 1017 certified, cUPC, CE listed, UL listed, BACnet Testing Laboratory (BTL) listed

IntelliStation Jr control module  
- BAS enabled  
- NVM (Non-volatile memory)  
- Touch screen interface



Actuator with manual override



Nursing Homes

**Key features include:**

- A programmable temperature set-back/scheduling program that lowers water temperature when the building is unoccupied
- Water temperature control to +/-2°F in accordance with ASSE 1017
- Field configurability and simplified installation
- Sanitization mode addressing waterborne bacteria
- BAS connectivity
- Software updates via Wi-Fi
- Now available in sizes 1.5" and 2"

Factory assembled and tested as complete system

Smart controller with 3.5" full-color, user-selectable touch screen display, passcode protected

High speed actuator with manual override

Integrated check valves prevent crossflow



**Typical Applications**

**Schools**



**Small Hotels/Motels**





# Why Water Mixing Is Critical in Providing Safe Water

Water plays an essential role in all our lives, but unmonitored and untempered, water can pose serious risks. IntelliStation solutions provide the capability to control water temperature to mitigate the risks posed by Legionella and other waterborne pathogens and to avoid scalding and thermal shock injuries.

## Legionella

According to the Centers for Disease Control (CDC), proper maintenance of water distribution systems is key to preventing illness from waterborne bacteria such as Legionella. Managers of commercial and institutional facilities know that selecting and controlling proper water temperature in their storage and delivery systems plays an important part in any maintenance program.<sup>2</sup>

In 2017, Centers for Medicaid & Medicare (CMS) issued a mandate based on ASHRAE 188 stating that hospitals must comply or risk losing Medicaid and Medicare reimbursements.

ASHRAE 188 is a standard that provides minimum requirements for limiting Legionella in building water systems.

According to Dr. Janet E. Stout, president and director of Special Pathogens Laboratory and research associate professor at the University of Pittsburgh Swanson School of Engineering in the Department of Civil and Environmental Engineering, 56% of Legionnaires' cases come from premise plumbing systems and 22% come from cooling towers.

### Legionella Growth Chart

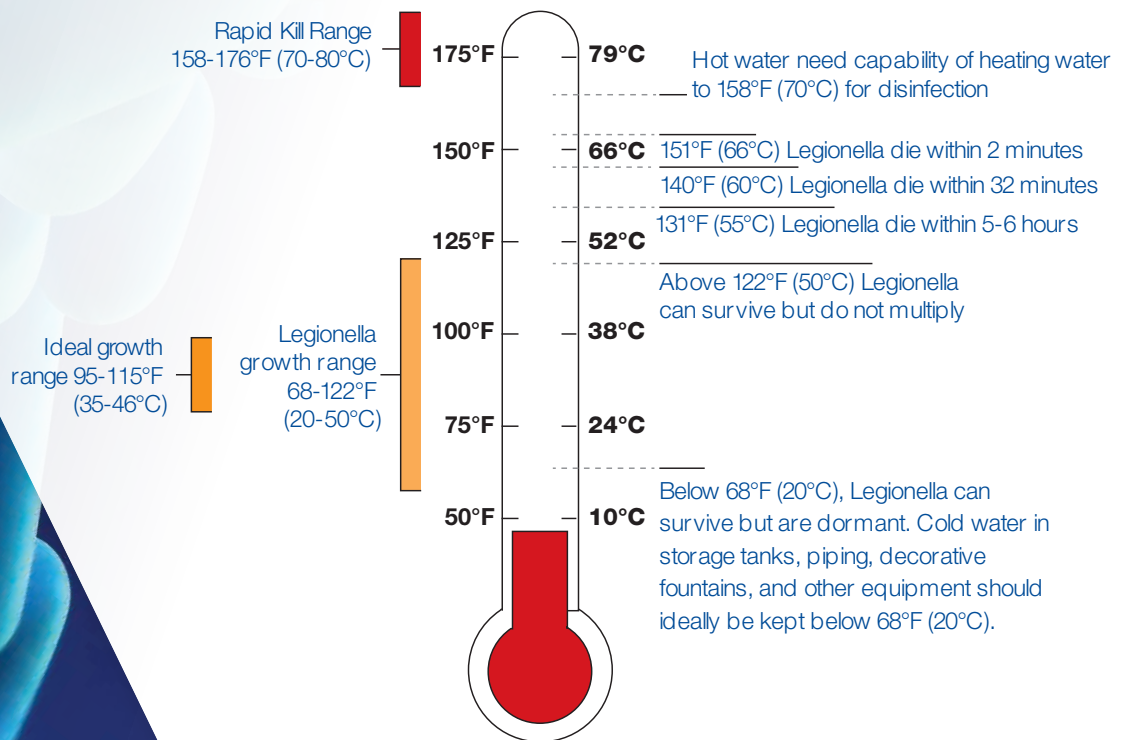

### Legionella Affects Thousands

*The CDC reported about 6,100 cases of Legionnaires' disease in the United States in 2016. The Institute estimates that one in ten people who get sick from Legionella will die.<sup>3</sup>*

## Scalding

The IntelliStation makes it easy to select and set a safe water temperature for your facility's residents and visitors to limit the risk of injuries resulting from scalding and thermal shock.<sup>4</sup>

Uncontrolled and unmonitored water distribution systems can create high-temperature scalding hazards in bathtubs, sinks and showers.

### Scalding Risk at Various Temperatures

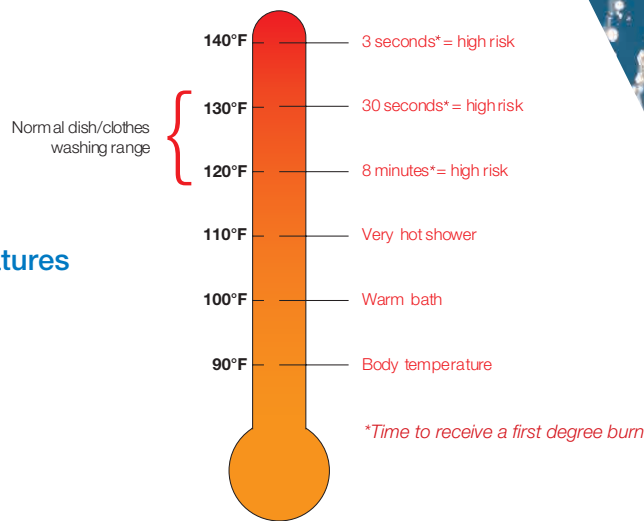

In 2003, approximately 21,000 children were treated for scald burns.

- Approximately 5,000 serious injuries from scalding tap water occur every year.
- 1,400 of those injuries result in overnight hospital stays and 34 result in deaths.
- Tap water burns account for up to 17% of all childhood burns requiring hospitalization.
- 85% of these deaths and injuries involve children under 15 and seniors over 65.<sup>5</sup>

## Thermal Shock

The thermal shock of a rapid and uncomfortable change in shower water temperature can cause a fall or serious injury. With the IntelliStation, stable mixed water is delivered to ASSE-listed thermostatic point-of-use devices to minimize this risk.

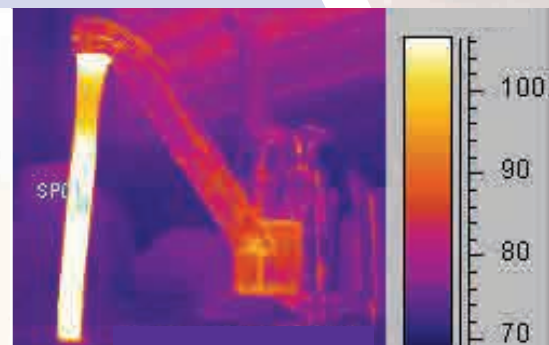





**CONNECT. CONTROL. CONSERVE.<sup>SM</sup>**

## The Future is here and It's Powered by Connections

Our smart and connected solutions are not only driven by your needs, but anchored by a promise to **connect** you to smart systems, help you **control** your systems for optimal performance, and **conserve** critical resources by increasing efficiency and innovative designs.

To learn more visit  
[Watts.com/Connect](http://Watts.com/Connect)

<sup>1</sup> Installation and adjustment of the IntelliStation are the responsibility of the owner and installer and must be done by qualified personnel in accordance with the manufacturer's instructions, and in compliance with all governmental requirements, building and construction codes and standards. The owner and user of the IntelliStation is responsible for selecting and installing the product in an appropriate water distribution system, proper sizing, maintaining proper water quality/condition, and deciding what temperature is safe and appropriate for the water distribution users and facility.

<sup>2</sup> The IntelliStation provides user-directed control and monitoring of water distribution systems. It is the user's responsibility to select and maintain water temperatures that are safe and appropriate for the water system users and facility. The IntelliStation's Sanitization mode is intended for use as part of a user-directed, controlled and supervised protocol that has been safely and properly designed. Always read and follow the User Guide & Instruction Manual and all product warnings and labels, and comply with all governmental and safety requirements.

<sup>3</sup> <https://www.cdc.gov/legionella/fastfacts.html>

<sup>4</sup> It is recommended to install IntelliStation as part of an ASSE 1017-compliant water distribution system, including point-of-use mixings valves that are listed to ASSE 1016, ASSE 1069, ASSE 1070 or ASSE 1071.

<sup>5</sup> <https://cultureofsafety.thesilverlining.com/childcare/tap-water-burns-and-scalds/>

# POWERS<sup>TM</sup>

A WATTS Brand

**USA:** Tel: (800) 669-5430 • Fax: (847) 229-0526 • [PowersControls.com](http://PowersControls.com)

**Canada:** Tel: (905) 332-4090 • Fax: (905) 332-7068 • [PowersControls.ca](http://PowersControls.ca)

**Latin America:** (52) 81-1001-8600 • [PowersControls.com](http://PowersControls.com)