

# Submittal

Job \_\_\_\_\_ Designer \_\_\_\_\_ Contact \_\_\_\_\_

## Invita™ WiFi Thermostat 564

The Invita™ WiFi Thermostat makes upgrading easy by using the existing 2-wires from any living space to connect to an HVAC Interface Module in the mechanical room. It works with most types of heating and cooling systems including conventional, heat pump and dual fuel while offering fan, relative humidity and ventilation control. The Invita Connect app provides secure WiFi adjustment, and can send email notifications when there are problems with the HVAC system. The Invita WiFi Thermostat is available in both white and black finishes and offers a choice of five display screen color themes.

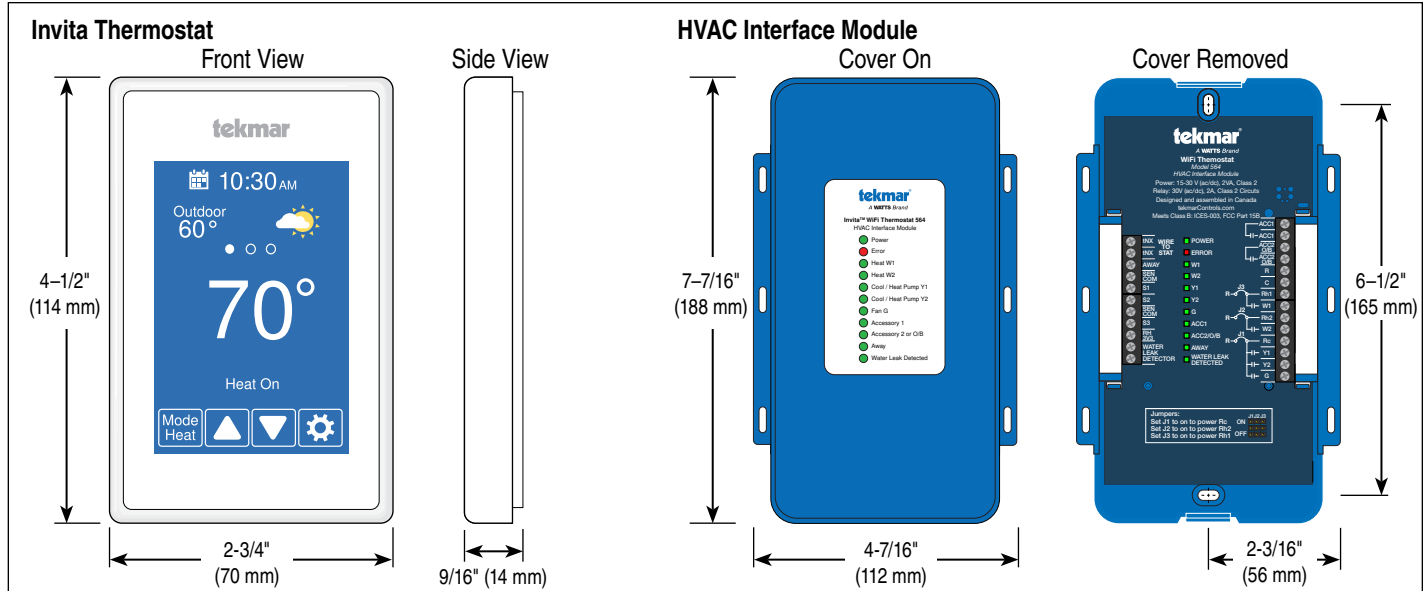

### Specifications

Invita™ WiFi Thermostat 564 Solves the 2-wire problem.	
Literature	Submittal, Quick Setup Guide, Operation Manual, User Manual, Job Record
Packaged weight	1.3 lb. (600 g)
Dimensions	Display: 4-1/2" H x 2-3/4" W x 9/16" D (114 x 70 x 14 mm) HVAC Interface Module: 7-7/16" H x 4-7/16" W x 1-1/4" D (188 x 112 x 31 mm)
Display	3.5" color touchscreen
Enclosure	Display: White or Black PVC plastic, NEMA type 1 HVAC Interface Module: Blue PVC plastic, NEMA type 1
Approvals	Meets Class B: ICES & FCC Part 15
Ambient conditions	Display: -4 to 122°F (-20 to 50°C), RH ≤90% non-condensing HVAC Interface Module: -40 to 122°F (-40 to 50°C), RH ≤90% non-condensing, outdoor use requires mounting in a NEMA 3 enclosure
Environmental	Do not use in presence of ammonia such as animal barns
Power supply	21 to 30 V (ac), 6 VA, Class 2
Relays	30V(ac), 2 A, Class 2 Circuits
Humidity sensor	0 to 90% ±4% RH
Temperature sensor	NTC thermistor, 10 kΩ @ 77°F (25°C ±0.2°C) β=3892
Optional sensors	tekmar type # 070, 072, 073, 076, 077, 079, 084, 086, 087
Communications	WiFi 802.11n, 2.4 GHz, WPA2 encryption
Mobile app	Apple iOS 11 or higher, Android 5 or higher
Languages	English/Français/Español
Warranty	3 Year Limited Warranty

### Works with

- Conventional systems
  - 2-stage heating, 2-stage cooling, fan and 2 accessories
- Heat pump & dual fuel systems:
  - 4-stage heating, 2-stage cooling, fan, reversing valve and 1 accessory
- Accessory options:
  - Humidifier, dehumidifier, HRV/ERV ventilator

### Features

- Remote access through Invita Connect mobile app or web browser
- Email notifications with option for alerts from Watts FloodSafe® Water Detector Shutoff
- Weather and outdoor temperature display
- Programmable schedule with early start
- Energy usage reports
- Relative humidity
- Ventilation
- Away energy saving mode
- 3 auxiliary sensor inputs
- Choice of black or white finish
- Multiple display colors
- Slim, 9/16" profile
- Wall plate trim included

**tekmar**<sup>®</sup>  
A WATTS Brand

# Example Application

Sample Mechanical diagram

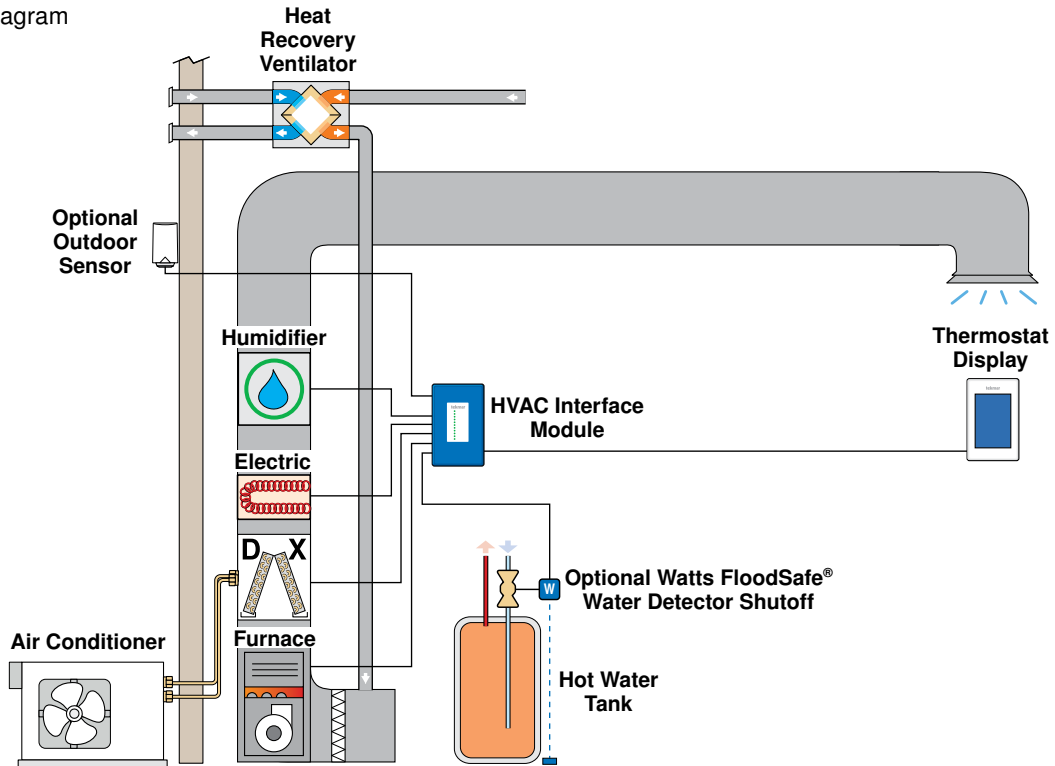

Sample Electrical diagram

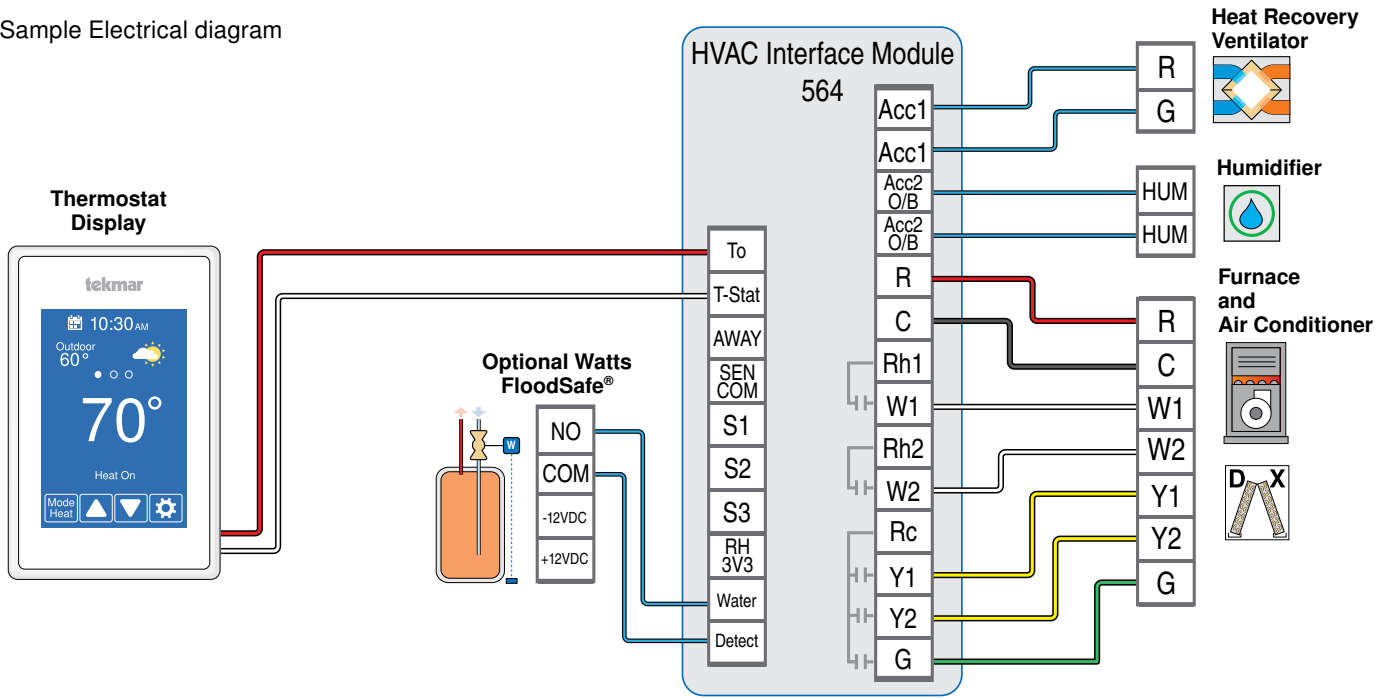

## CAUTION

This Submittal is not intended to provide full installation instructions and safety information. In order to avoid property damage or injury, please refer to the complete installation manual and product safety information provided with the product.



A WATTS Brand

All specifications are subject to change without notice.

Tel: 1-800-438-3903 • F: (250) 984-0815  
tekmarControls.com